

Education in Mali is in crisis.

How can education be brought to the Malian people?

61.3%
of the Malian population aged 15 and older can neither read nor write.



UNESCO (2015). Literacy Data Statistical Tables. Retrieved from <http://www.uis.unesco.org/literacy/>

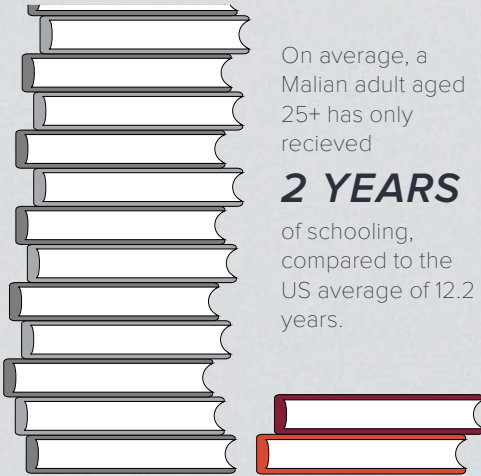

UNESCO (2011). Literacy Data Statistical Tables. Retrieved from <http://www.uis.unesco.org/literacy/>

70% of Malians live in rural areas.

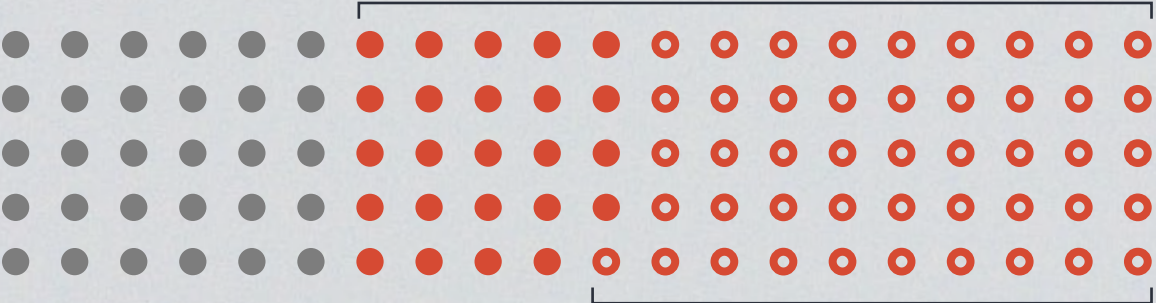

2/3 of rural children do not have access to a school.

Empower Mali. (2016) Facts About Education in Mali. Retrieved from <http://www.empowermali.org/>



Arne Hoel of The World Bank. (2006). Young girl walks to school [Photograph]. Retrieved from <https://flic.kr/p/8Ld2m6>

What are the components of a mobile education space?

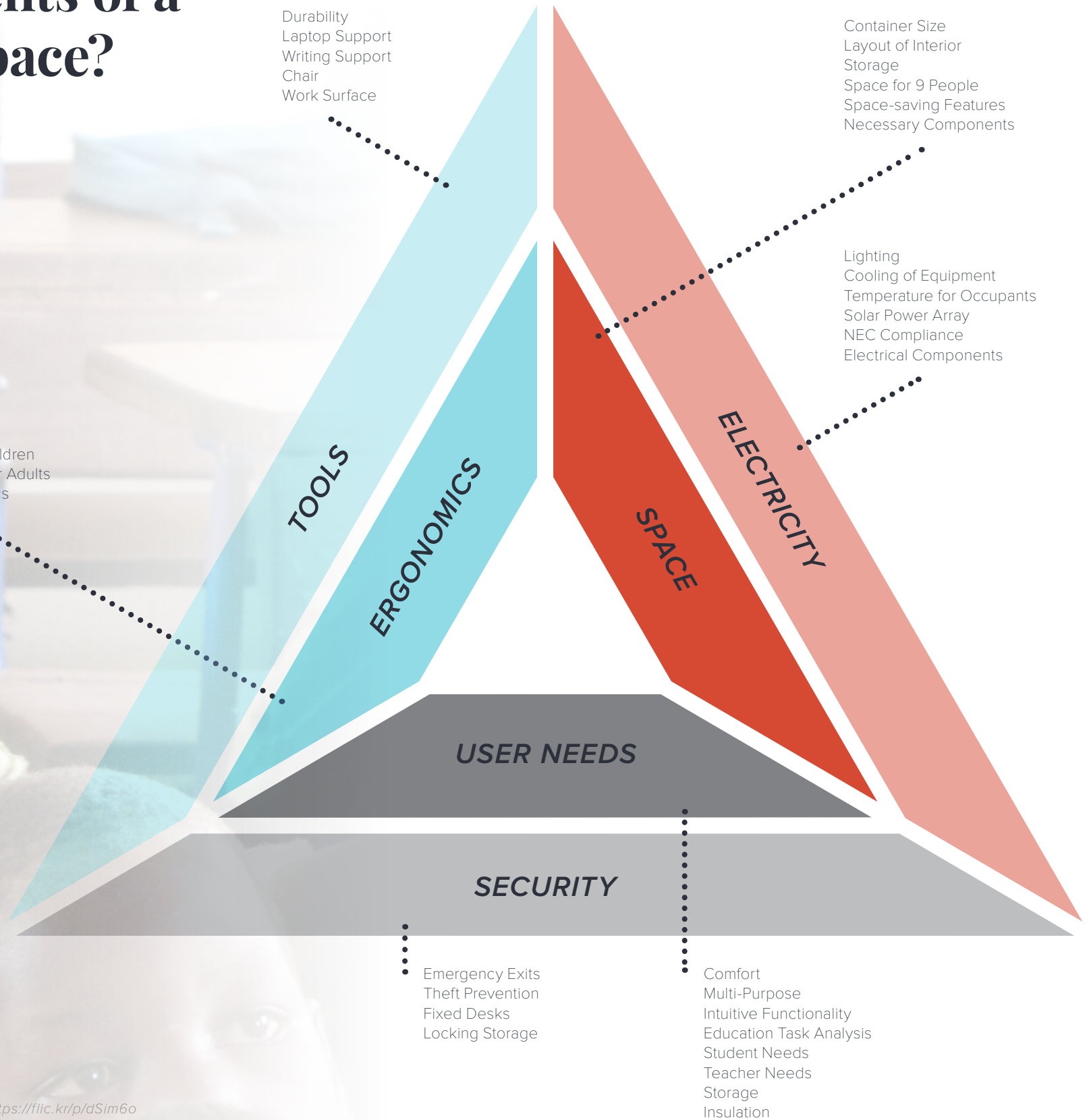

KERFED FOLD-UP
DESK CONCEPT

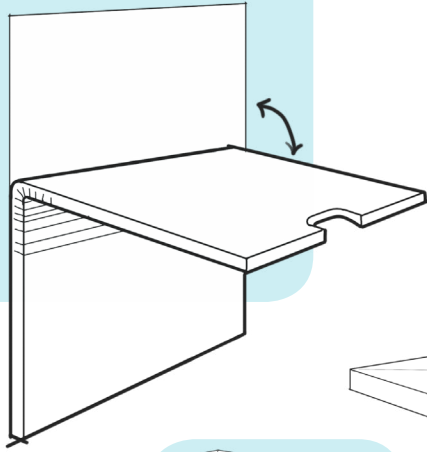

2-WAY FOLDING
DESK CONCEPT

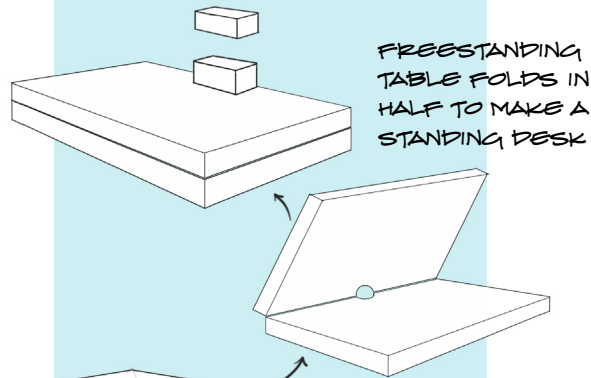

FREESTANDING
TABLE FOLDS IN
HALF TO MAKE A
STANDING DESK

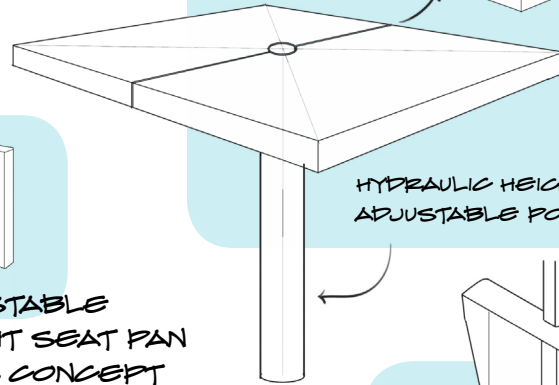

HYDRAULIC HEIGHT
ADJUSTABLE POST

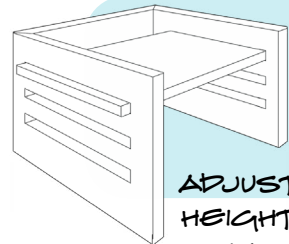

ADJUSTABLE
HEIGHT SEAT PAN
CHAIR CONCEPT

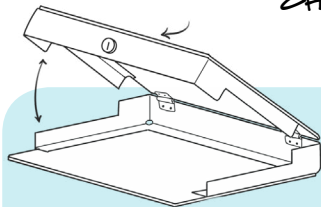

HALF-SHELL
DESK & CHAIR
CONCEPT

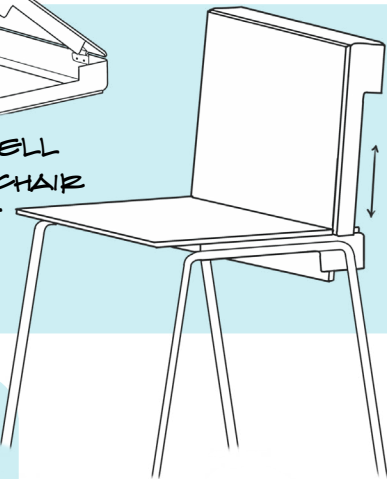

REMOVABLE
BACK REST
CHAIR
CONCEPT

HINGED BACK
REST CHAIR
CONCEPT

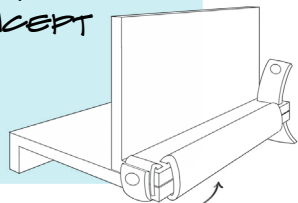

FABRIC HINGE & INDUSTRIAL
SNAP CLOSURE ATTACHMENTS

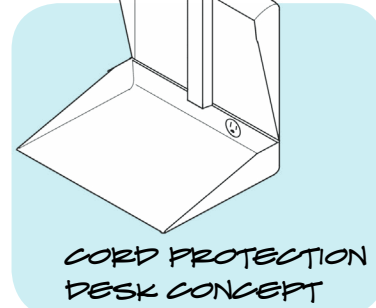

CORD PROTECTION
DESK CONCEPT

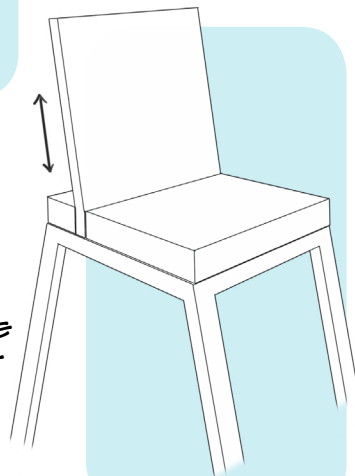

WRITING SURFACE
WHEN CLOSED

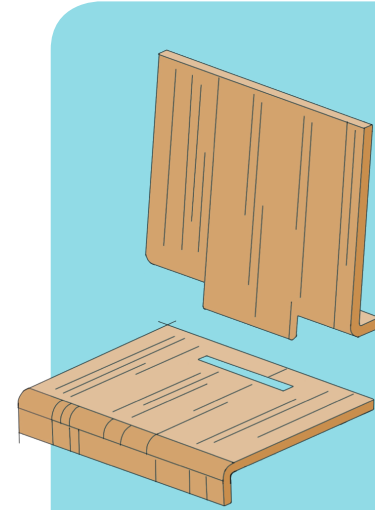
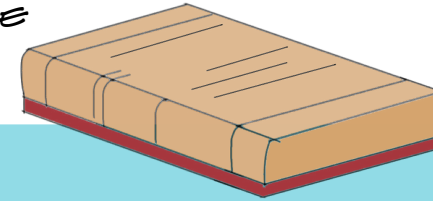

CHAIR WITHOUT BACK,
DEEP ENOUGH FOR
LARGE ADULT

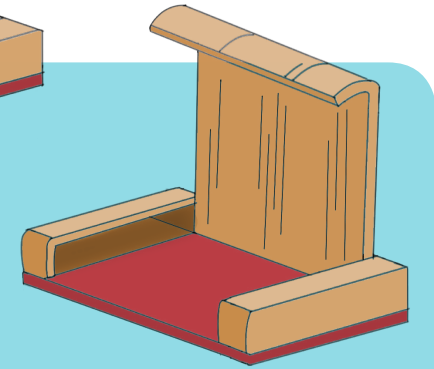

LAPTOP STORED
INSIDE DESK,
ALLOWS FOR
INSTALLATION OF A
LOCKING MECHANISM

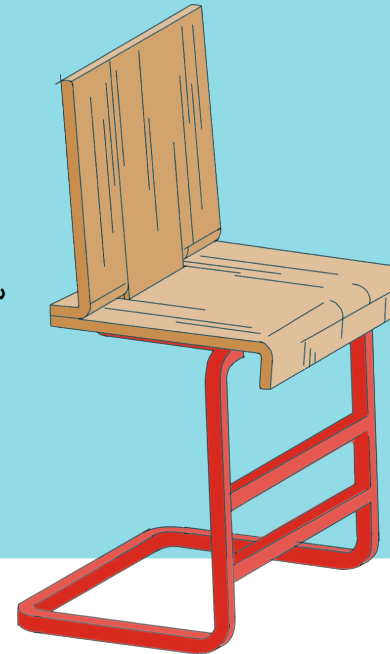

CHAIR WITH BACK,
DEEP ENOUGH FOR
SMALL CHILD,
SUPPORTIVE FOOT
RESTS AT TWO
HEIGHTS

CNC MANUFACTURING,
GLUE-UP ASSEMBLY
OF PLYWOOD PIECES

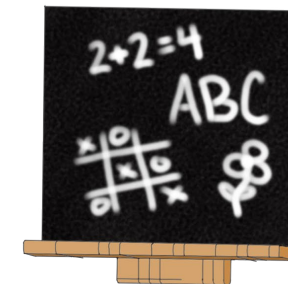
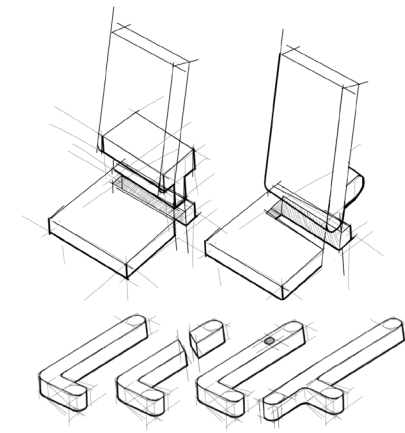

REMOVABLE
BACK, DOUBLES
AS CHALKBOARD
TABLET

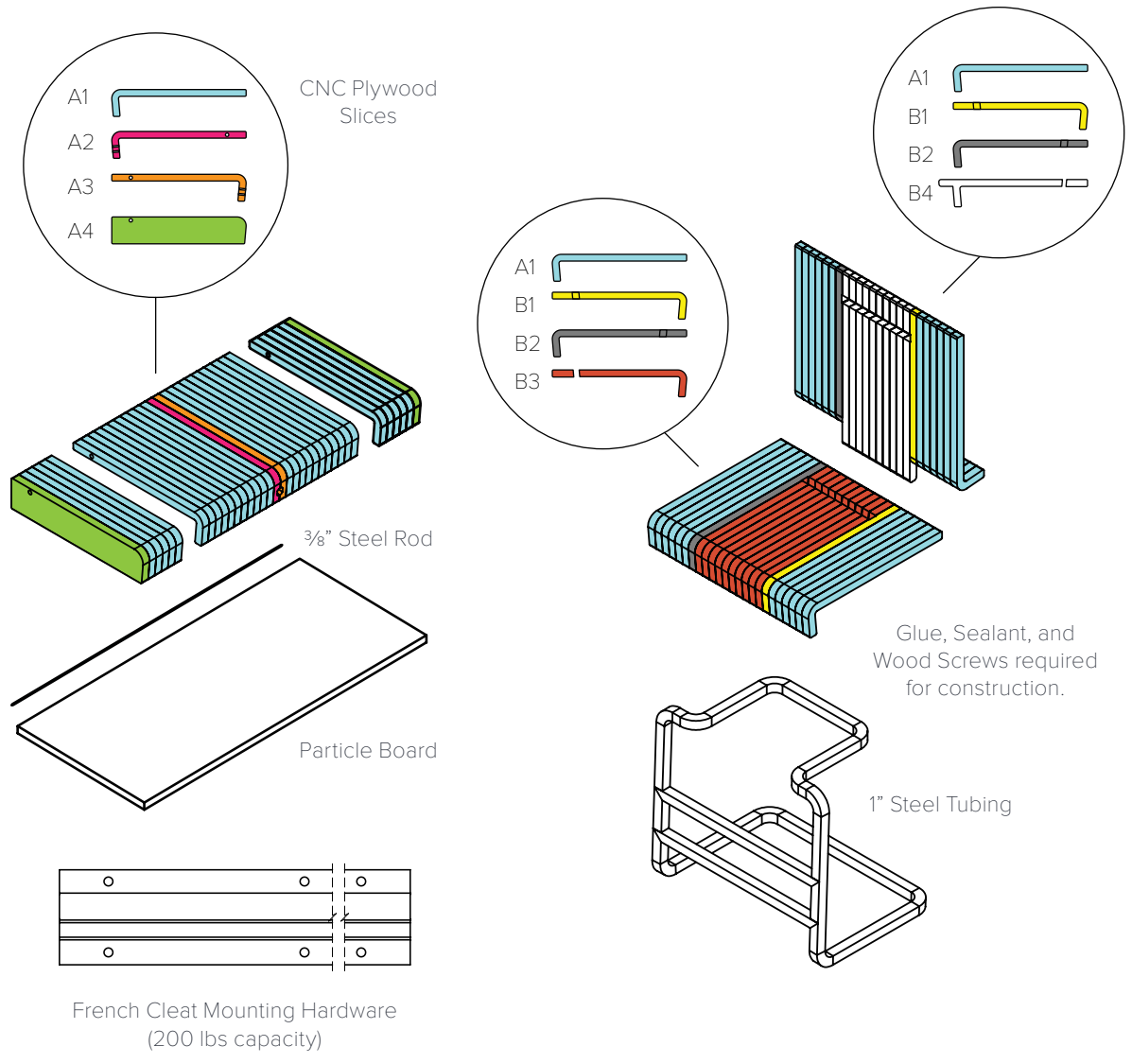

Images from Prototype Validation, Captured by Ashley Lincoln with permission from participants.

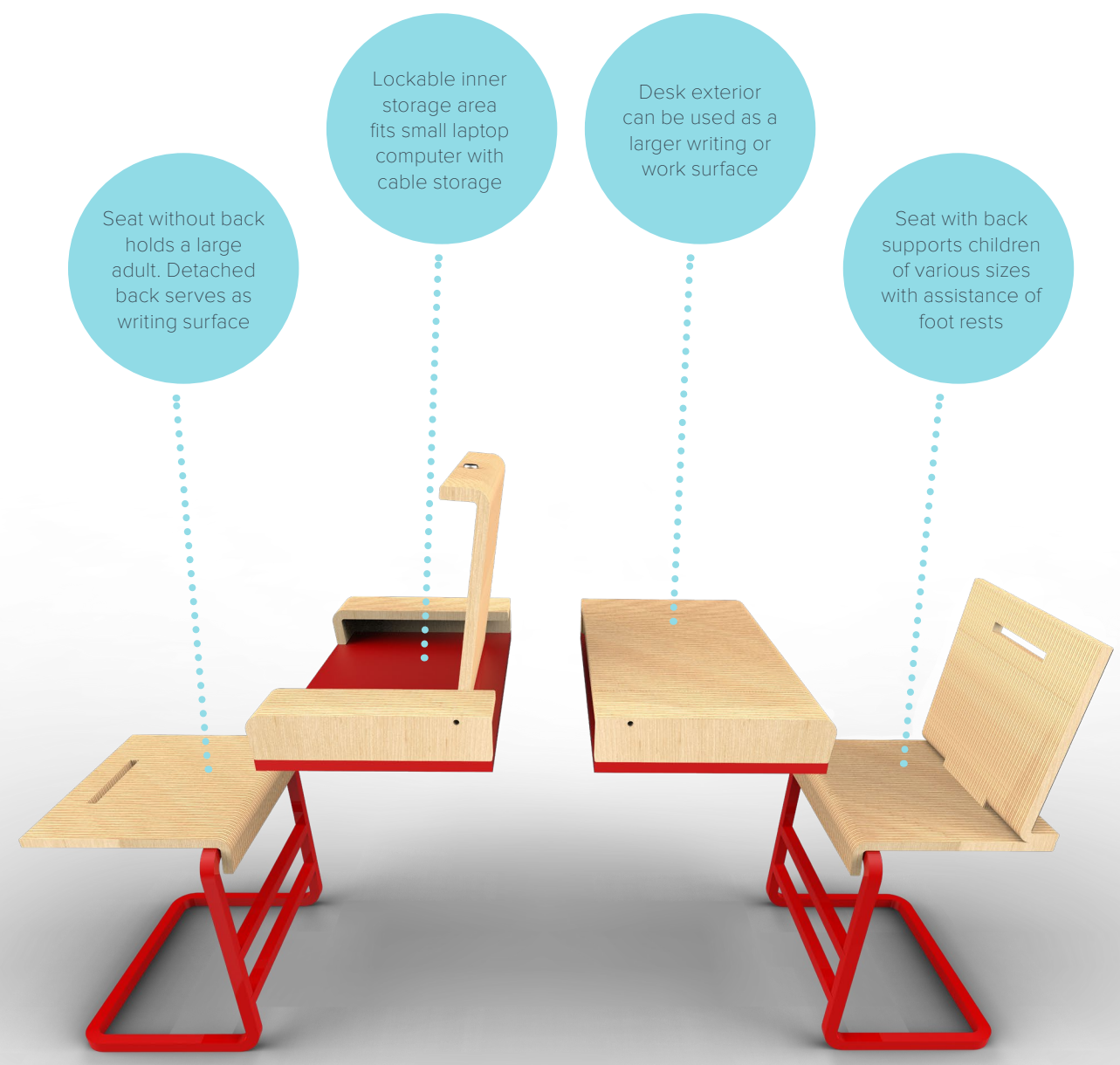

MATERIAL COSTS (RETAIL)

3/4" Plywood Sheet	\$25
Particle Board	\$5
1" Steel Tubing	\$20
Fasteners	\$3
Finishing Materials	\$15
Mounting Hardware	\$14
Total Cost	\$82

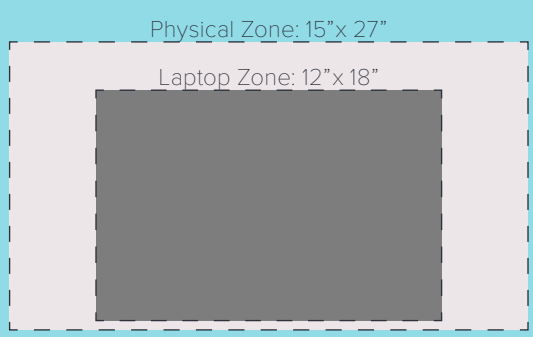

1-10 SCALE WORKSPACE SIZE



References

"Basic Education and Gender Equality." UNICEF. N.p., n.d. Web. 10 May 2016. <http://www.unicef.org/education/index_44870.html>.

"Education System in Mali." Mali Education System. N.p., n.d. Web. 10 May 2016. <http://www.classbase.com/countries/Mali/Education-System>

"Statistics-Mali." UNICEF. N.p., n.d. Web. 10 May 2016. <http://www.unicef.org/infobycountry/mali_statistics.html>

Churchill, E., Laubach, L., McConville, J. T., & Tebbetts, I. (1978). Anthropometric source book. Volume 1: Anthropometry for designers (Vol. 1). Houston, TX: NASA.

Institute of Electrical and Electronics Engineers, American National Standards Institute, & IEEE-SA Standards Board. (2011). National Electrical Safety Code. New York: Institute of Electrical and Electronics Engineers. Retrieved from <http://ieeexplore.ieee.org/servlet/opac?punumber=5967875>

Lenovo ThinkPad X201 3626 review. (n.d.). Retrieved May 10, 2016, from <http://www.cnet.com/products/lenovo-thinkpad-x201-3626/>

Lueder, R., & Rice, V. (2008). Ergonomics for Children: Designing Products and Places for Toddler to Teens.

United States Department of Labor. (n.d.). Computer Workstations eTool. Retrieved May 1, 2018, from <https://www.osha.gov/SLTC/etools/computerworkstations/index.html>

World Health Organization. (n.d.). The WHO Child Growth Standards. Retrieved from <http://www.who.int/childgrowth/en/>

World Health Organization | Mali. (n.d.). Retrieved May 10, 2016, from <http://www.who.int/nutgrowthdb/database/countries/mli/en/>